

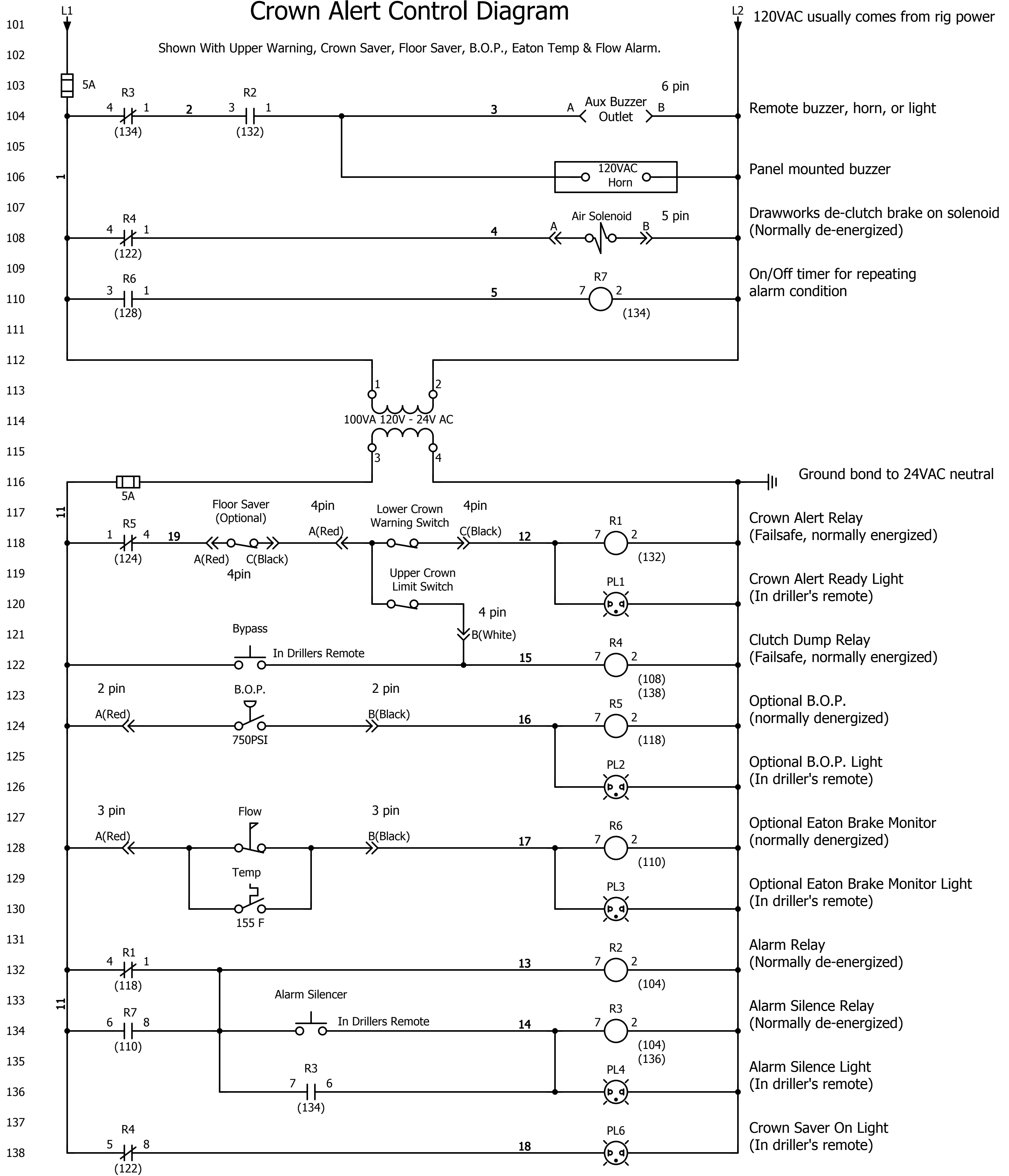

Crown Alert Control Diagram

Shown With Upper Warning, Crown Saver, Floor Saver, B.O.P., Eaton Temp & Flow Alarm.



- Note: upper and lower crown limit switches are often combined into one unit

- No reproduction without the permission of the author/designer
 Developed by: Bruce McKenzie Dec. 1998

 <p>Mustang Controls LTD. P.O. Box 5062 Devon, AB T9G 1X8 Ph: (780) 987-7300 Fax: (780) 987-0106 E-mail: Info@mustangcontrols.com</p>	Project Name: Crown Alert Control Panel		
	Scale: 1:1	Sheet: 1 Of 7	Revision: 1
Last Change: 2010.11.08			
Job Number: Generation 1			
Checked By: BM			